



# SUPERIOR VACUUM PERFORMANCE

## COMPARED TO OTHER CANISTER VACUUMS

- » **UP TO 2X THE PERFORMANCE**
- » **5X THE VACUUM LIFE**

Longest motor life in the industry, approximately 5,000 hours or 3-5 years. Lasts 5-10 times longer than traditional canister vacuums.

## FEATURES & BENEFITS

- + Attractive Design & Easy Installation & Maintenance
- + **Exclusive Filter Maintenance Indicator Light**
- + Long-life Pleated Filter Bags can be Washed or Replaced
- + High Flow, User-friendly Hose
- + Dual Voltage Design - 110v/220v

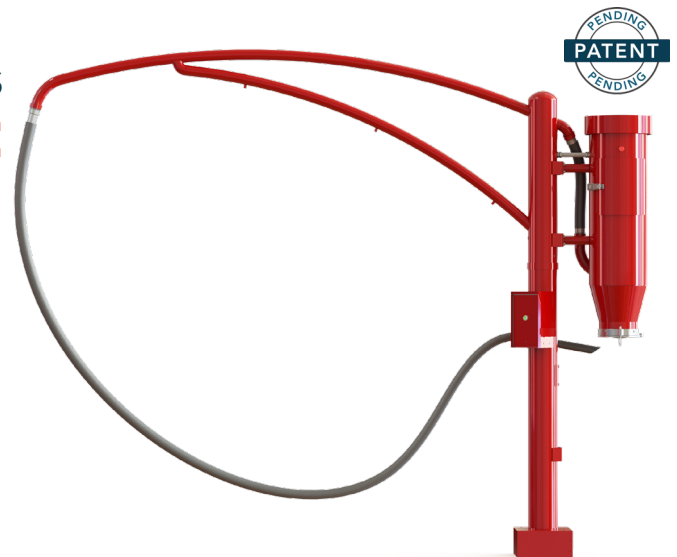

**NCS**  
PROFITABLE SOLUTIONS  
YOUR CAR WASH EXPERTS

National Carwash Solutions | 1500 SE 37th Street, Grimes, IA 50111 | (800) 284-7956 | [NCSWASH.com](http://NCSWASH.com)

NCS reserves the right to revise designs, make corrections, add or delete features and change specifications at any time without notice or obligation.

## STANDARD OFFERINGS

- + Colors: Silver, Red or Blue
- + LED Light
- + Push-button Activation
- + Gray Hose with Crevice Tool

## OPTIONAL FEATURES

- + Air Kit (Requires air source and supply lines)
- + Trash Can (Stanchion-mounted)

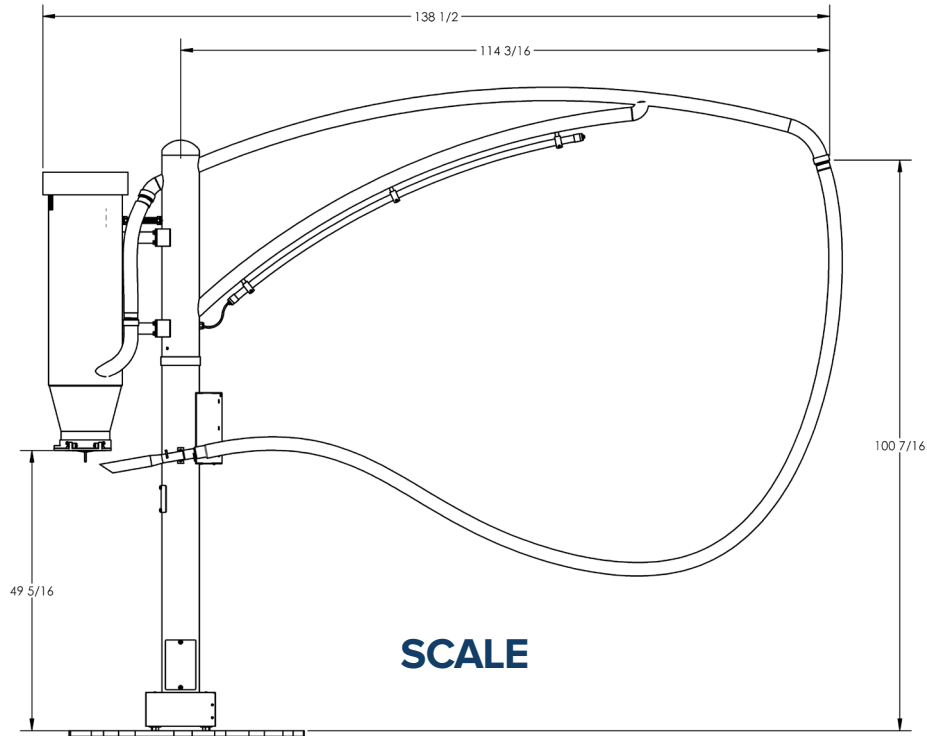

**CONTACT US FOR ADDITIONAL DIMENSIONS AND INSTALLATION SPECIFICATIONS.**

